

Advanced Low NOx Technology

Since 1930, Clayton has been a leader in the development and manufacture of innovative and highly efficient Steam Generators. Backed by worldwide sales and service, our unique Steam Generators have proven the superiority and ability to provide reliable, cost effective steam production around the world. Working from proven designs and philosophies, our commitment to continuing research and development has made Clayton one of the most respected names in the boiler industry. In keeping with this strong background we are pleased to introduce our latest product line of very Low NOx - Low CO Steam Generators. These unique combustion systems provide extremely low emissions without sacrificing efficiency and reliability. Clayton's clean emissions technology is "**not just a step ahead, but A STEP BEYOND.**"

Clayton Steam Generators:

- **SAVE FUEL**
The unique counter flow design provides higher fuel-to-steam efficiency than traditional boilers.
- **ARE SAFE FOR PERSONNEL AND EQUIPMENT**
Inherently safe, the Clayton design eliminates hazardous steam explosions.
- **PROVIDE RAPID RESPONSE**
The Clayton design responds rapidly to sudden or fluctuating load demands.
- **START FAST**
The Clayton design will provide full output from a cold start within fifteen minutes, without thermal stress.
- **ARE COMPACT AND LIGHTWEIGHT**
The Clayton design typically occupies one-third of the floor space and weighs 75% less than a traditional boiler.
- **ENSURES HIGH QUALITY STEAM**
Clayton provides a 99.5% quality separator to minimize moisture in the steam.
- **OFFERS ADVANCED CONTROLS**
PLC controls, Variable Speed Drives and a linkage-less servo controlled burner management system are standard.
- **INCLUDES OUTSTANDING SUPPORT**
Every Steam Generator is backed by Clayton factory direct sales and service plus full service feedwater treatment.



E204 200 BHP
Steam Generator

Ultra Low NOx Burner

Clayton's Low NOx - Low CO Fiber Metal Burner (FMB) system achieves low emissions through a combination of technologies including improved fuel and air mixing, ultra lean flame design and a low flame residence time. The fiber metal allows for a very short flame length which results in ultra low NOx emissions.

The system consists of a high pressure combustion air blower, fuel/air premixing chamber, modulating air/fuel damper, premix plenum, fiber metal burner manifold and an advanced micro-ratio adjustable fuel flow control system. Air and gas are thoroughly mixed in the premix chamber and air/fuel damper and then introduced into the combustion chamber via the premix plenum and burner manifold.

The system is automatically controlled and is capable of a nominal 4:1 turn-down ratio.

The Clayton low emissions fiber metal burner is available for use on natural gas and propane gas only in sizes from 50 BHP to 750 BHP.

Typical emissions are 9 ppm NOx and 50 ppm CO, or lower, corrected to 3% O₂.

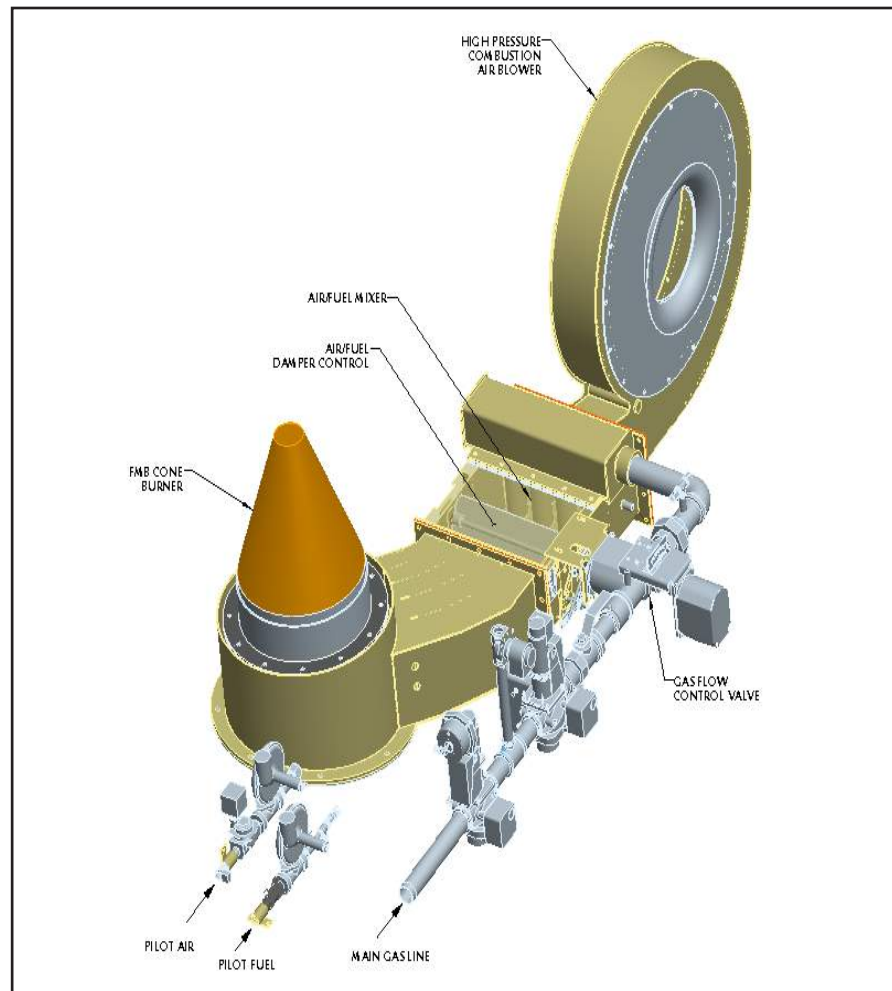

Flue Gas Recirculation



Clayton's Flue Gas Recirculation (FGR) system is an effective method for reducing the NOx levels in flue gas emissions. Two primary factors contribute to the production of NOx when fuel is burned, combustion temperature and oxygen. By recirculating a portion of the flue gas into the combustion chamber, the combustion temperature and oxygen levels are effectively reduced - by as much as 60%.

The flue gas is drawn from the exhaust stack into the forced draft blower through an induction process that uses air velocity to create a vacuum. The vacuum changes in proportion to the combustion air rate change, causing a self regulating effect on the FGR rate, relative to the combustion air rate. Effective NOx reduction typically requires 15-20% flue gas recirculation.

The system is automatically controlled and is capable of a nominal 4:1 turn-down ratio.

The Clayton flue gas recirculation system is available for use on natural gas, propane gas and #2 fuel oil in sizes from 150 BHP to 750 BHP.

Typical emissions on gas are below 30 ppm NOx and 100 ppm CO. Typical emissions on #2 fuel oil are below 90 ppm NOx and 400 ppm CO. Both corrected to 3% O2

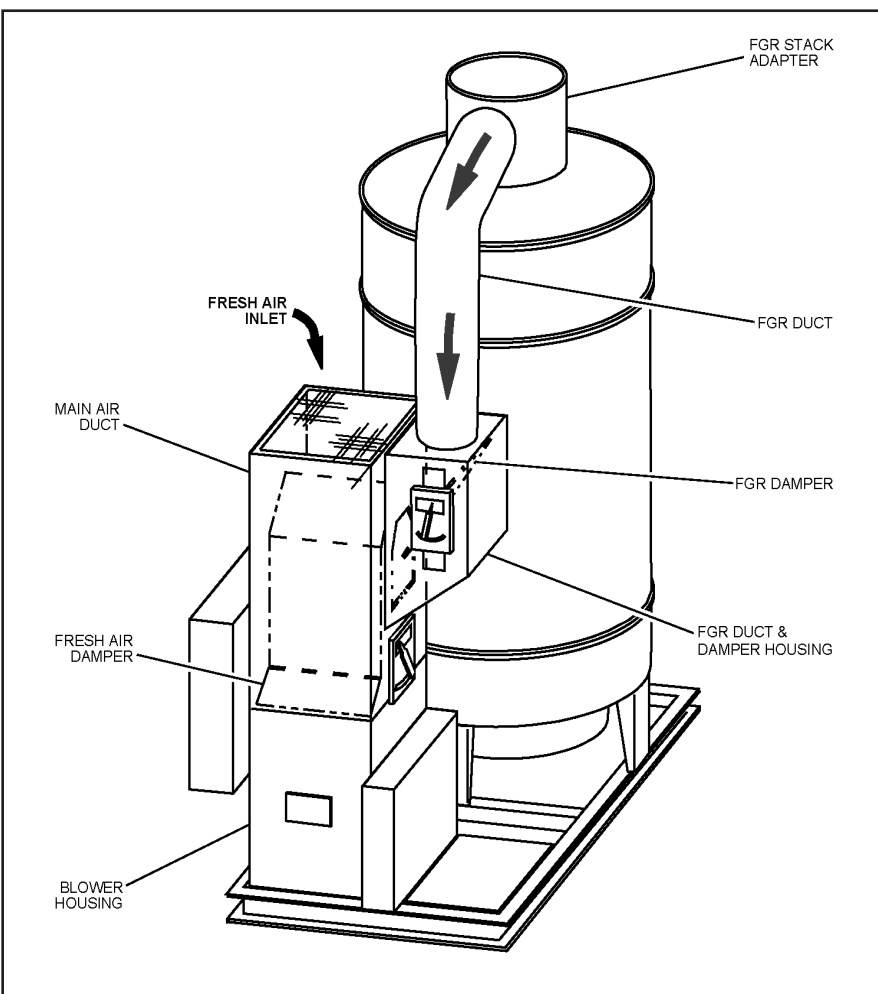

Your Single Source For Steam Technology Since 1930



Industry has turned to Clayton Steam Generators time and again over the decades, simply because they do so many things so well. From single unit packaged skids to complex multi-unit installations plus heat recovery in CHP projects, Clayton Steam Generators supply premium steam as a vital ingredient in your process, boosting in-plant efficiency, lowering costs and economizing on fuel.



Clayton Steam Generators, setting world standards since 1930 for operating efficiency, fuel savings and safety, are backed by extraordinary customer service. Factory direct service technicians provide start-up and training plus preventative maintenance programs tailored to fit your company's needs. In addition, Clayton offers a complete line of Coil Guard water treatment chemicals supported by a dedicated chemical service group.

Clayton INDUSTRIES

Your Single Source for Steam Technology Since 1930

World Headquarters

17477 Hurley Street
City of Industry, CA 91744
800.423.4585 tel • 626.435.0180 fax
email: sales@claytonindustries.com
www.claytonindustries.com

Europe, Africa & Middle East Headquarters

Rijksweg 30 • B-2880 Bornem, Belgium
32.3.890.5700 tel • 32.3.890.5701 fax
email: sales@clayton.be
www.clayton.be

Latin America Headquarters

Manuel L. Stampa 54 • Nueva Industrial Vallejo
Mexico D.F., 07700 Mexico
Toll Free: 01.800.888.4422 • (55)55.86.51.00 tel
(55)55.86.23.00 fax • email: claytonmexico@clayton.com.mx
www.claytonmexico.com.mx

ATLANTA • BOSTON • CHICAGO • CINCINNATI • CLEVELAND • DALLAS • DETROIT • KANSAS CITY • NEW YORK/NEW JERSEY • SAN FRANCISCO

Clayton Deutschland GmbH
Clayton Thermal Products Ltd (UK)

Clayton Scandinavia A.S.
Clayton Nederland B.V.

Clayton de France S.A.R.L.
Clayton Sales & Service Canada

World Leaders in Precision Steam Generators, Fluid Heaters, Heat Recovery Systems and Customer Service